

# VENTURI SPACE



MEDIA KIT

“

WE'RE HARNESSING OUR EXPERTISE FOR SPACE RESEARCH,  
WHERE EXCELLENCE IS SIMPLY THE STANDARD.

| Gildo Pastor, President of Venturi Space and Venturi |

”



After two decades of innovation in terrestrial electric vehicles, Venturi's President Gildo Pastor has repositioned the firm in the space sector, aiming to forge new collaborations with NASA and ESA.

The change of strategy ties in with NASA's Artemis programme that will see humanity return to the Moon in 2030, after the US space agency invited bids from contractors to design, manufacture, and operate a lunar terrain vehicle for transporting astronauts and equipment.

In 2024, NASA pre-selected the rover FLEX from the American company Venturi Astrolab, Inc. Its strategic partner, Venturi Space, is in charge of designing and manufacturing the hyper-deformable wheels (in Switzerland), the batteries (in Monaco) and the battery management systems (in France).

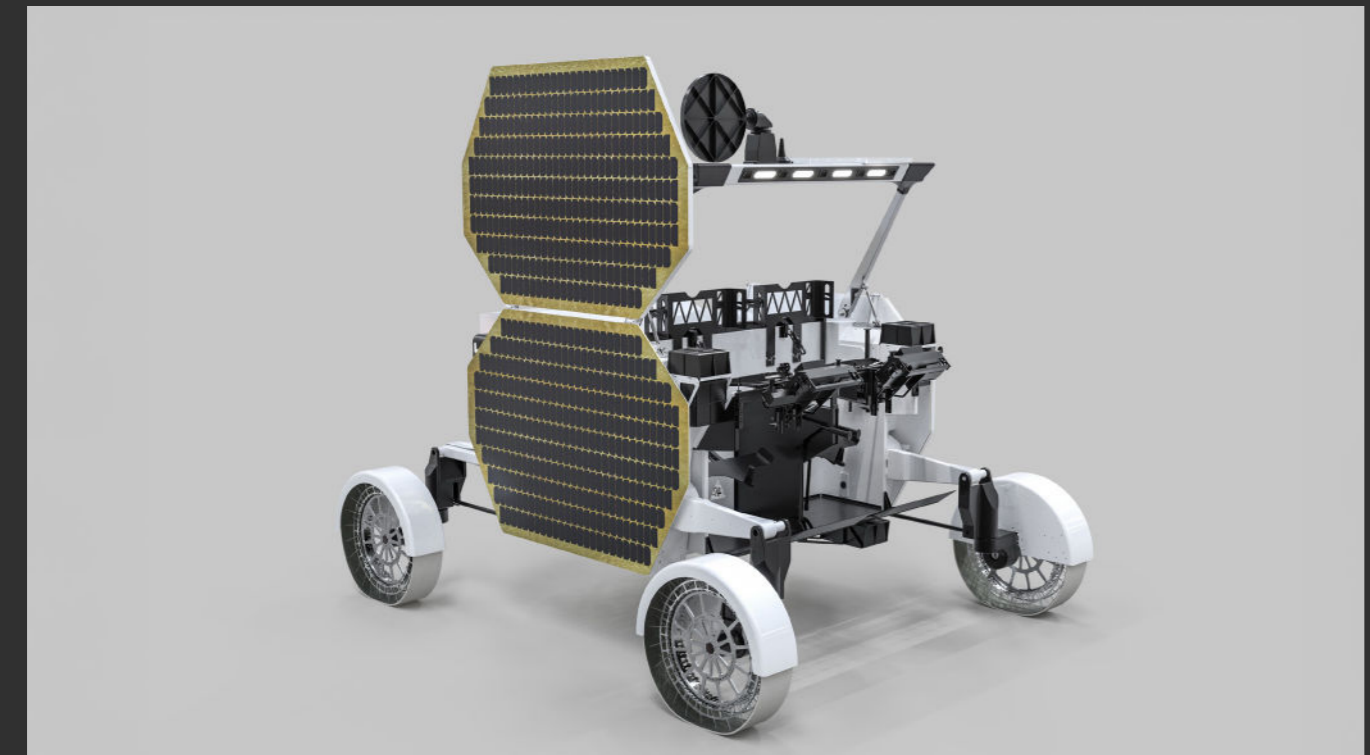

# FLEX

2028 with SpaceX and Venturi Astrolab, Inc.

The astromobile, designed by Sacha Lakic, will be transported in 2028 to the lunar South Pole by SpaceX.

Controlled remotely from Earth, it will conduct scientific experiments and commercial activities.

In the meantime, NASA may select the vehicle.

Consequently, from 2030 onwards, most of the rover's operational time would be devoted to missions for the US space agency. Outside these missions, the rover would carry on its activities for private purposes.

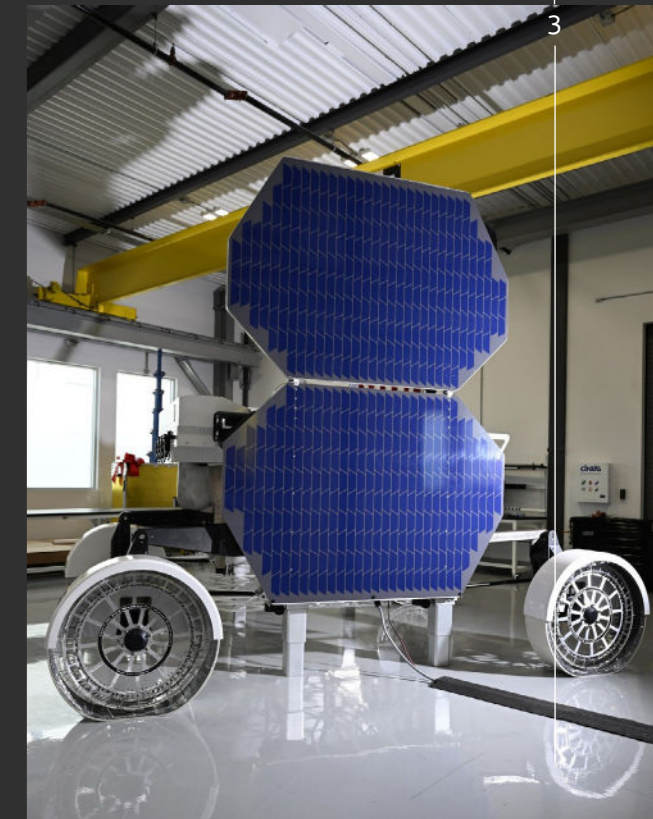
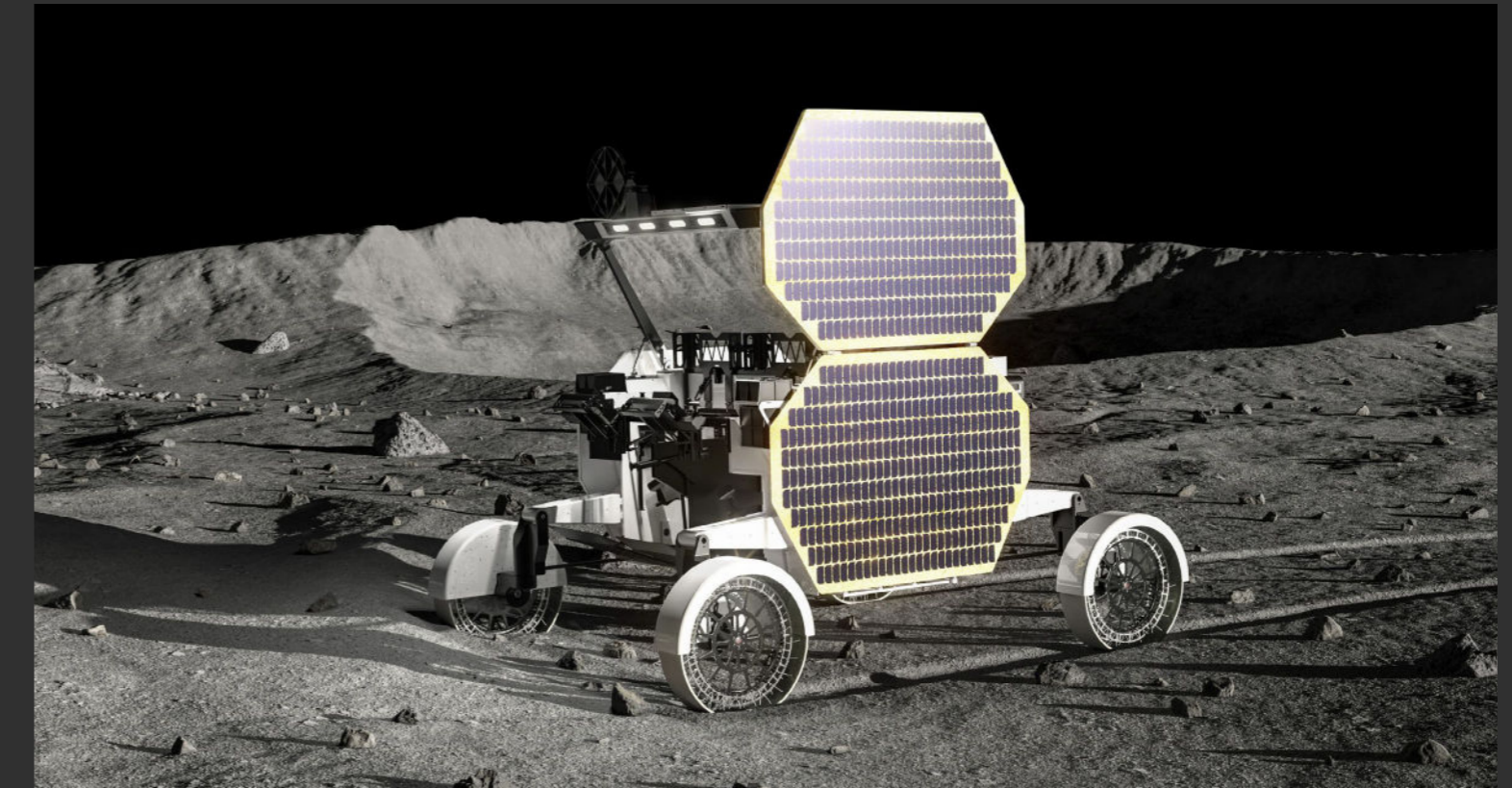

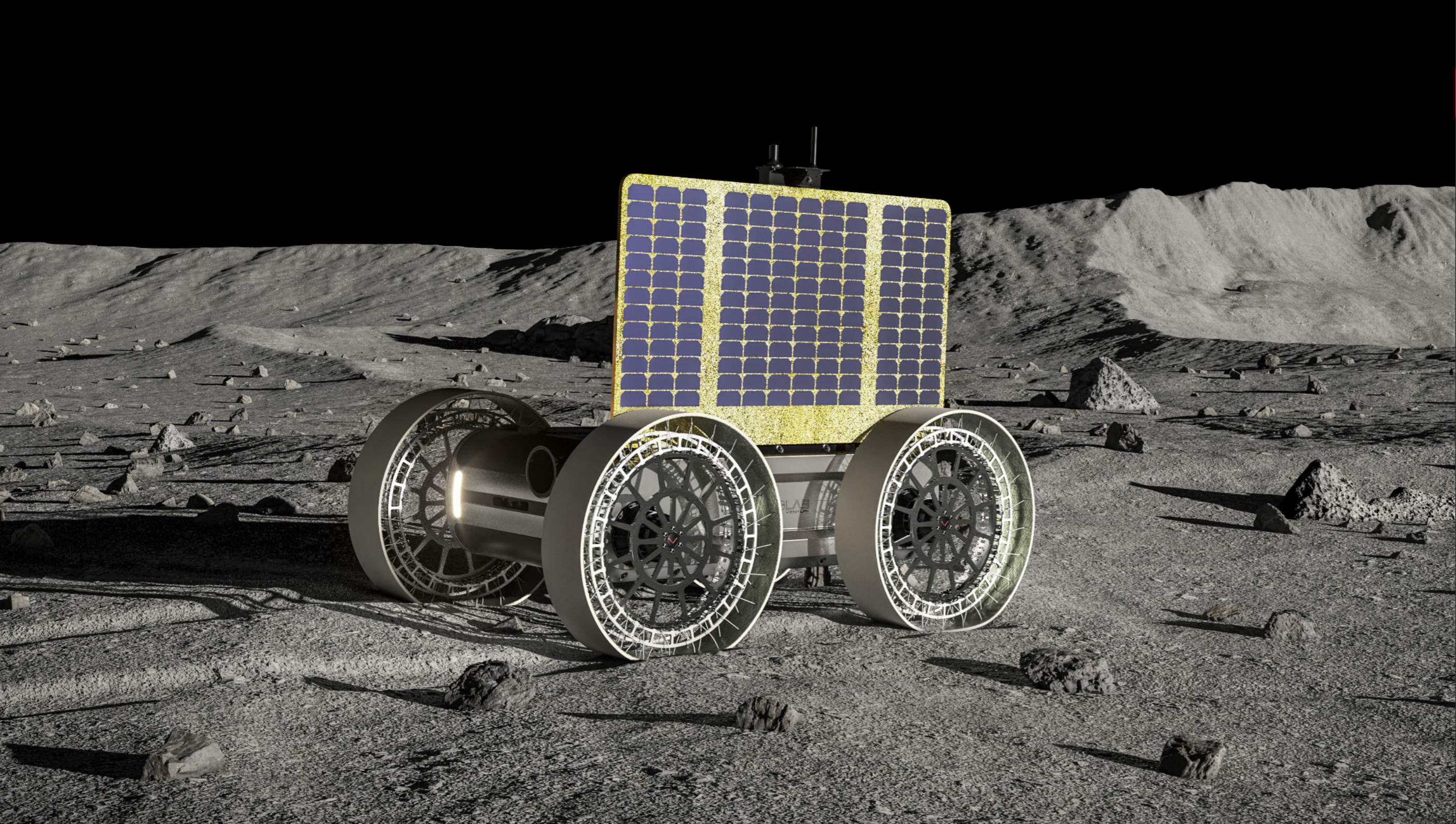

## FLIP

2026 with Venturi Astrolab, Inc. and Astrobotic

### FLIP (Flex Lunar Innovation Platform)

Astrobotic's Griffin lander will deliver, with the SpaceX's Falcon Heavy rocket, Venturi Astrolab's FLIP rover to the South Pole of the Moon as part of Astrobotic's Griffin Mission One (Griffin-1) scheduled for delivery in 2026.

As a strategic partner, Venturi Space plays a critical role in this mission in the development of FLIP. We design and manufacture the rover's hyper-deformable wheels and high-performance batteries, ensuring optimal mobility and power supply in the Moon's extreme environment.

### Why design another rover?

FLIP, also designed by [Sacha Lakic](#), is structured to respond to the growing number of institutional, businesses and scientific organizations in the U.S. and European markets, that are seeking access to the Moon for smaller payloads.

WATCH THE VIDEO 

# MONA LUNA

Designed and tailored for ESA and CNES

A project led by Venturi Space France

Venturi Space France will oversee MONA LUNA's development and space qualification from its base in Toulouse, coordinating every aspect of the process: onboard electronics, avionics, space-to-ground links, energy management systems, assembly, final integration, and acceptance testing in readiness for space flight.

All with one clear objective: to deploy MONA LUNA at the Moon's South Pole by 2030.

Using technology made in Europe

MONA LUNA is designed to be carried into space by the Ariane 6.4 launch system and landed on the Moon's surface by the European Argonaut lunar lander, while the rover itself will be equipped with a robotic arm to handle scientific instruments and payloads.

WATCH THE VIDEO

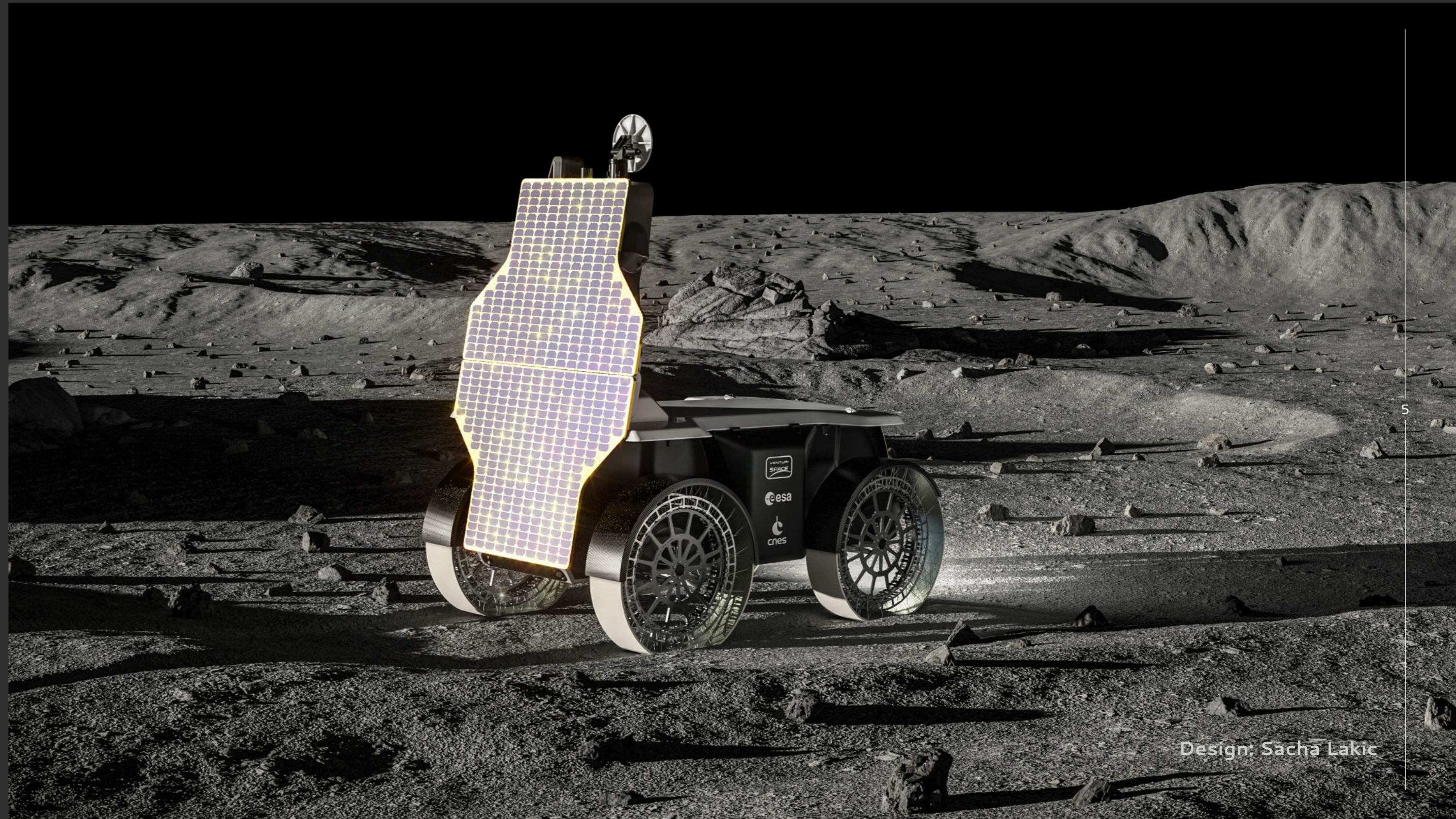

Design: Sacha Lakic

# MARS

## From the Moon to Mars

Building on the experience gained with the FLEX lunar rover and in response to the US decision to advance Mars exploration missions, Venturi Astrolab, Inc. have taken the initiative to design and build a versatile Mars rover.

Leveraging the foundation of the FLEX rover, we have adapted its technologies and instruments to deliver comprehensive services on Mars, targeting both private and public institutions.

This rover will be fully autonomous during its future missions while remaining capable of remote control.

Its primary mission will be to detect and extract water using an integrated drill and probe.

### The mission has two main goals:

- Split water into oxygen and hydrogen
- Combine this water with the carbon dioxide in the Martian atmosphere to produce oxygen and methane, enabling spacecraft refueling

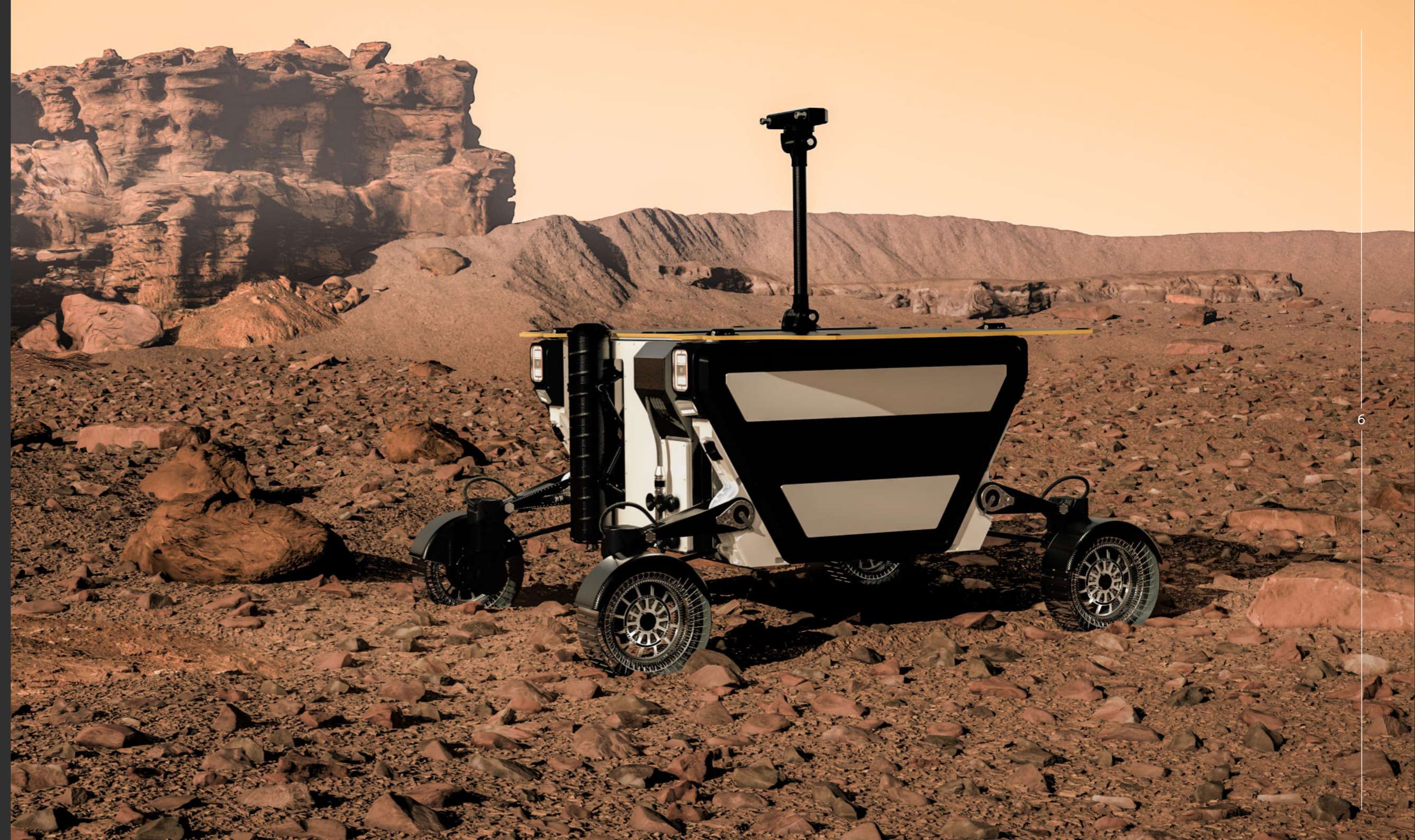

# WHEELS

## WHY has Venturi Space reinvented the wheel?

Advanced technology wheels exist, but the engineers, chemists and physicists at Venturi Space Switzerland have designed a unique, hyper-deformable lunar wheel. Why develop this breakthrough technology based on unique materials?

## TO ACCOMMODATE numerous significant challenges.

Solutions used on vehicles for the Apollo lunar mission and Curiosity Mars rover are not suitable, nor are terrestrial pneumatic tyres.

## HOW has Venturi reinvented the wheel?

To achieve this breakthrough, as important as the invention of the rubber, and later pneumatic rimmed tyre in the 19th century, the Swiss teams of Dr. Antonio Delfino developed a system that required the invention of new materials.

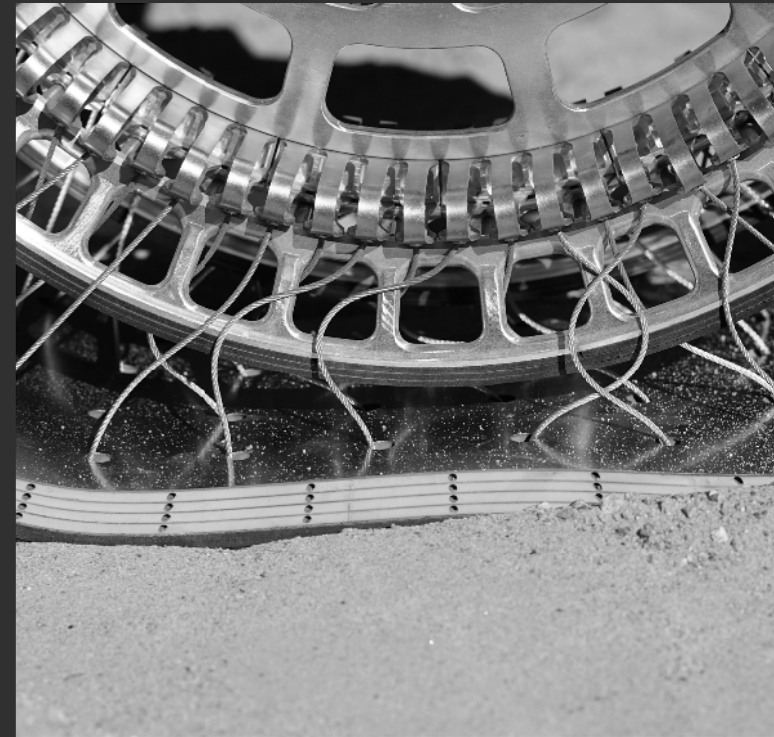
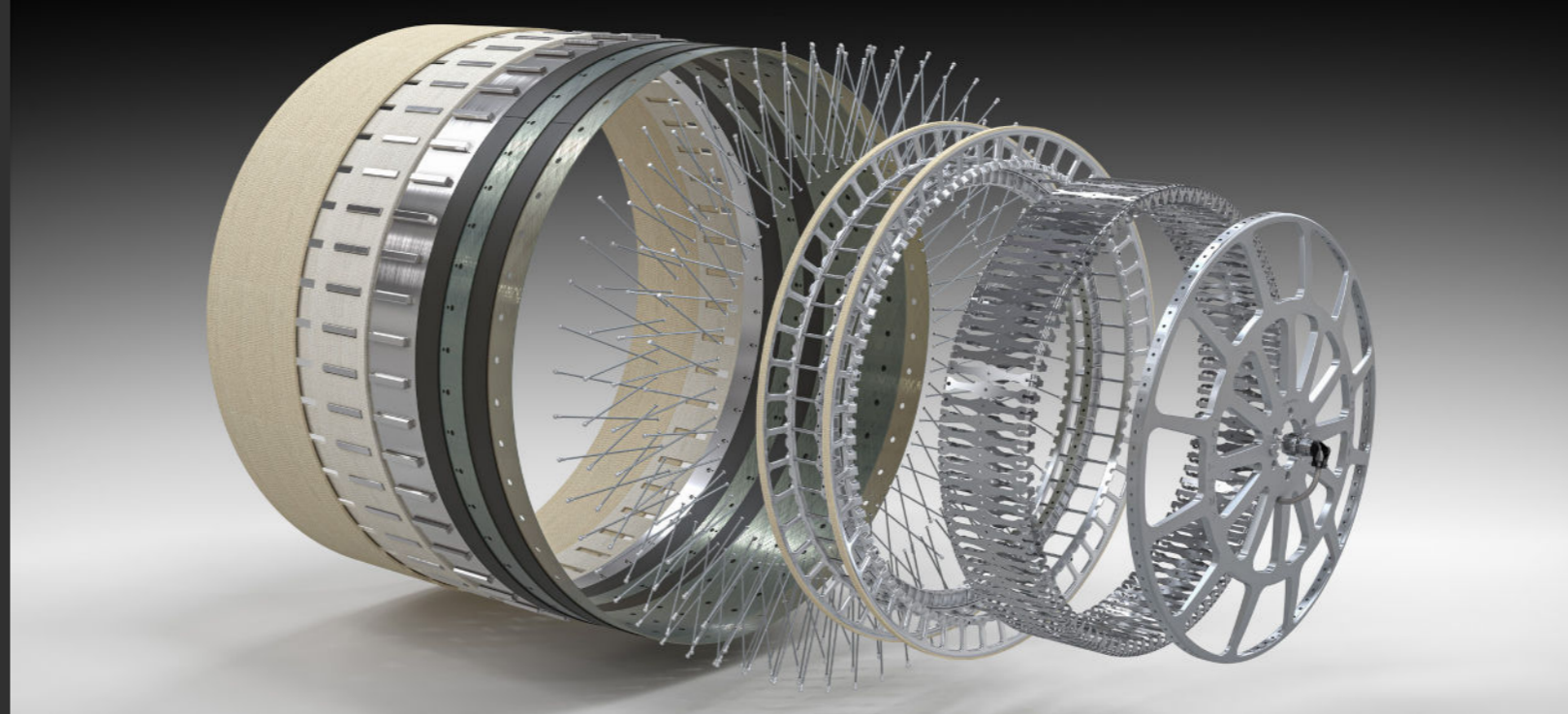

### WHEEL CHALLENGES AND CAPABILITIES

	FLEX 2027 > ...	Apollo LRV MISSIONS 1971 > 1972	Curiosity 2011 > ...	TERRESTRIAL TYRE
Works without atmosphere	✓	✓	✓	✗
Puncture proof	✓	✓	✓	✗
Radiation resistant	✓	✓	✓	✗
Supports a weight of 2T while travelling at 15 km/h	✓	✗	✗	✓
Works in temperatures up to -240 °C	✓	✗	✗	✗
Durable for over 5,000 km	✓	✗	✗	✓

# BATTERIES

Venturi Space batteries are designed to withstand the extreme temperatures and intense solar radiation at the lunar south pole.

## CELL TESTING

To power the rovers, Venturi Space acquires and tests cells, **90%** of them are selected.

## TEMPERATURE RESISTANCE: **-240°C**

The battery packs are designed to withstand an external temperature variation close to 400°C (from -240°C up to +130°C).

## OVERCHARGE PROTECTION: **4.2V**

The cells are subjected to an overcharge test by charging them beyond the 4.2V voltage limit, at which point the charge interruption device is triggered.

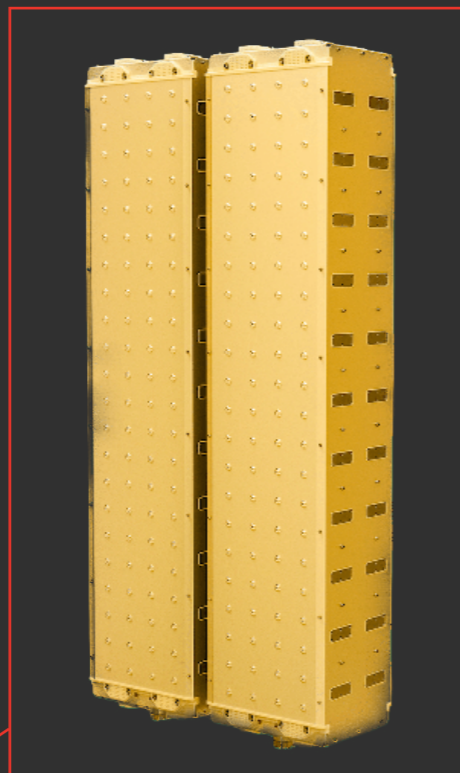

## EXTERNAL SHORT CIRCUIT **PROTECTION**

The cells are tested to prevent thermal runaway. In the event of a short circuit, an internal protection device activates and the cell potential falls to 0V.

## BATTERY **PACKS**

Each rover is equipped with several battery packs to ensure functional redundancy. The battery design provides protection against the propagation of thermal runaway, in order to preserve its functionality.

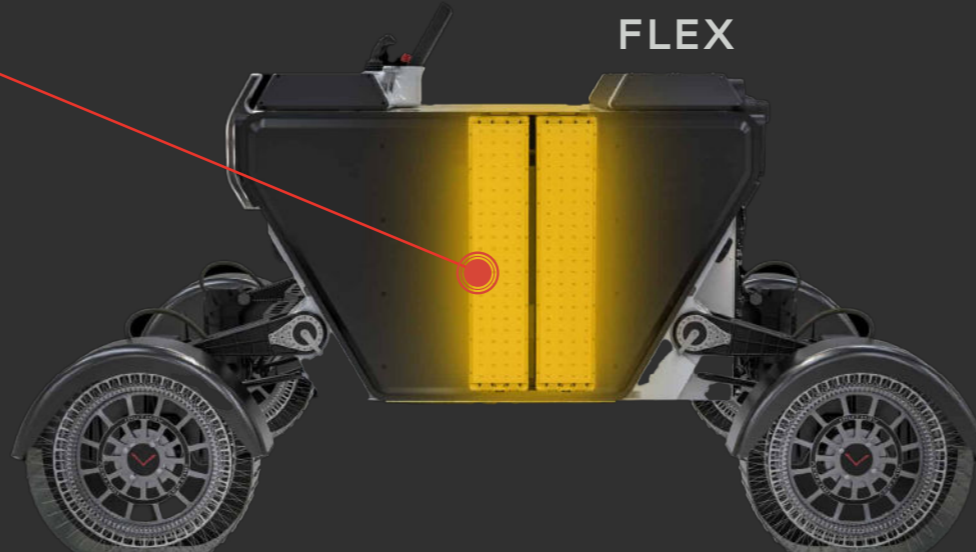
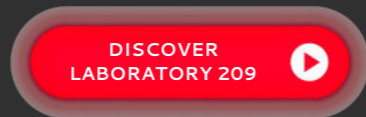
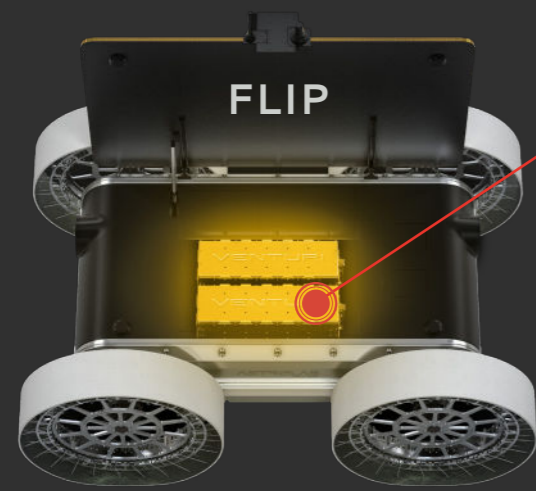

# - ÉQUILIBRE -

AN ORIGINAL CREATION BY SACHA LAKIC FOR VENTURI SPACE

*Unveiled at the 55th edition of the International Paris Air and Space Show*

“Équilibre” is a manifesto-sculpture – a suspended moment between gravity and ascension, between the conquest of space and our connection to humanity.

The vehicle, inspired by Venturi Space’s lunar mobility design, no longer rests on its four wheels: it defies earthly logic. Its balance relies on a single point of contact – the left rear wheel – set upon a metallic base that evokes the rippling imprint of an impact on liquid. Though solid, this base symbolises the fragility of our bond with planet Earth.

At the opposite end, a cosmonaut clings to the front right wheel, his legs reaching skyward. He appears to be gently resisting the forces pulling him – not towards the Moon, but to an unnamed elsewhere. His body floats, yet his spirit remains tethered to what he is leaving behind.

Crafted entirely in satin-finished aluminium, the piece plays with light, tension, and disorientation.

It does not depict a technical scene or a futuristic tableau, but rather a metaphor for our times – torn between escaping into the unknown and the urgent need to restore balance here.

“Équilibre” captures that fleeting moment where everything could still tip – or fall into harmony.

┌ **This is not a work about technology.**  
**This is not a work about conquest.**  
**It is a work about the necessity of keeping our humanity**  
**in motion.** └



## PRESS CONTACT

Fabrice Brouwers  
HEAD OF COMMUNICATIONS

+33 (0)6 40 61 00 80

[fbrouwers@venturi.com](mailto:fbrouwers@venturi.com)

## CONTACT

7, rue du Gabian  
98 000 MONACO

+377 99 99 52 00

[info@venturi.com](mailto:info@venturi.com)

[www.venturi.space](http://www.venturi.space)



@venturi



@venturi.official